

BALLOSTAR®

KHE-FL

Long flange design

GENERAL FEATURES

- » 2-piece ball valve with full bore
- » Floating ball, antistatic, lockable
- » Fire Safe
- » Modular system components

CONNECTIONS

Flange in accordance with EN 1092-1 (VIII, Xc)

DIMENSIONS

Face-to-face dimensions in accordance with EN 558-1, series 1

ACCEPTANCE TESTING

- » Seat leak tightness: EN 12266-1 P12, leakage rate A
- » Tightness to atmosphere: EN 12266-1 P11
- » Strength: EN 12266-1 P10

AUTOMATION

Flange connection in accordance with ISO 5211, allows for direct mounting of an actuator or by means of brackets. Pneumatic and electrical actuators utilizable.

TEMPERATURE

-60 °C to +300 °C (see pT diagram)

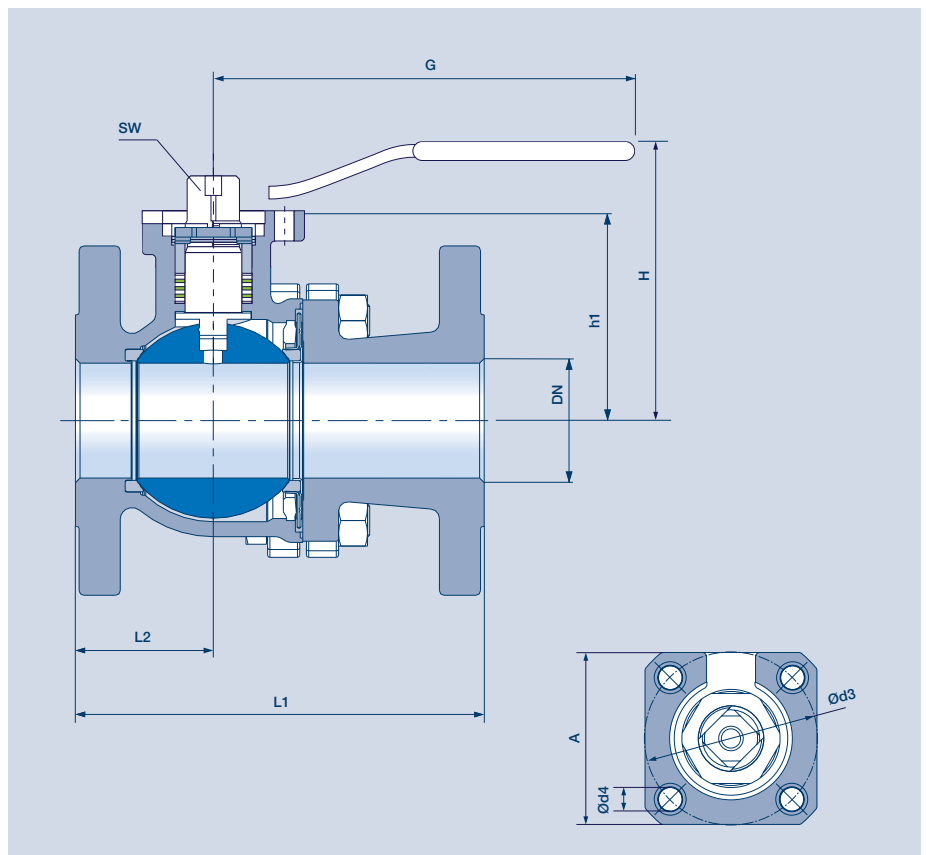

KHE-FL VARIANTS

PRESSURE RANGE PN 40

Material: Steel casting 1.0619 (Material code VIII)
Stainless steel casting 1.4408 (Material code Xc)

DN	Dimensions						PN		Mounting flange for actuator				Weight kg	
	L1	L2	H	G	h1	lz*	VIII	Xc	ISO	SW	A	Ød3		Ød4
15	130	50	80	130	35	4	40	40	F04	8	42	42	5.8	2.4
20	150	45	94	160	46	4	40	40	F04	11	42	42	5.8	3.6
25	160	45	98	160	50	4	40	40	F04	11	42	42	5.8	4.5
32	180	50	106	250	65	4	40	40	F05	14	50	50	7	6.9
40	200	50	113	250	72	4	40	40	F05	14	50	50	7	8.8
50	230	60	131	315	90	4	40	40	F07	17	70	70	10	13.6
65	290	65	141	315	100	8	40	40	F07	17	70	70	10	19.5
80	310	65	162	500	122	8	40	40	F10	22	102	102	12	28.4
100	350	75	176	500	135	8	40	40	F10	22	102	102	12	38.7
125	400	125	211	650	175	8	40	40	F12	27	125	125	15	67.4
65	290	65	141	315	100	4	16	16	F07	17	70	70	10	19.5
100	350	75	176	500	135	8	16	16	F10	22	102	102	12	38.7
125	400	125	211	650	175	8	16	16	F12	27	125	125	15	67.4

PRESSURE RANGE PN 16**

Material: Steel casting 1.0619 (Material code VIII)
Stainless steel casting 1.4408 (Material code Xc)

* Number of bores

** In accordance with the norm, the flange face-to-face dimensions of the nominal pipe sizes DN 15-50 as well as DN 80 are the same for PN 16 and PN 40 variants.